

# Plasma and TIG processes. Automatic welding applications

Performance and high productivity  
in boiler and pipe work.

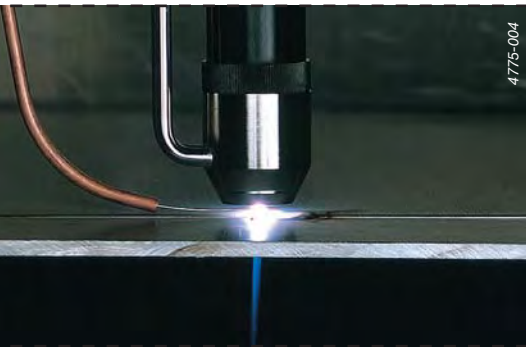

# Plasma and TIG processes used in automatic applica



The plasma arc: a natural phenomenon tamed by Air Liquide Welding. The term plasma applies to gases at temperatures exceeding 3000 °C at atmospheric pressure. On the temperature scale, it can be regarded as the fourth state of matter after the solid, liquid and gaseous states.

The plasma arc is now widely used in the steel, chemical and mechanical engineering industries. As market leader in this sector, Air Liquide Welding has turned it into a powerful cutting and welding tool. It is generally accepted that the plasma welding process is the major technological advance from inert gas shielded free arc welding (the TIG process).

**Plasma arc: high temperatures, a concentrated beam, better productivity.**

The isotherm diagram opposite shows clearly that the energy distribution is strongly modified within the plasma arc:

- the 16 000 °K to 24 000 °K temperature zone is outside the nozzle,
- the 10 000 °K to 16 000 °K temperature zone is entirely transferred to the workpiece and causes the “key hole” effect (penetration of the workpiece).

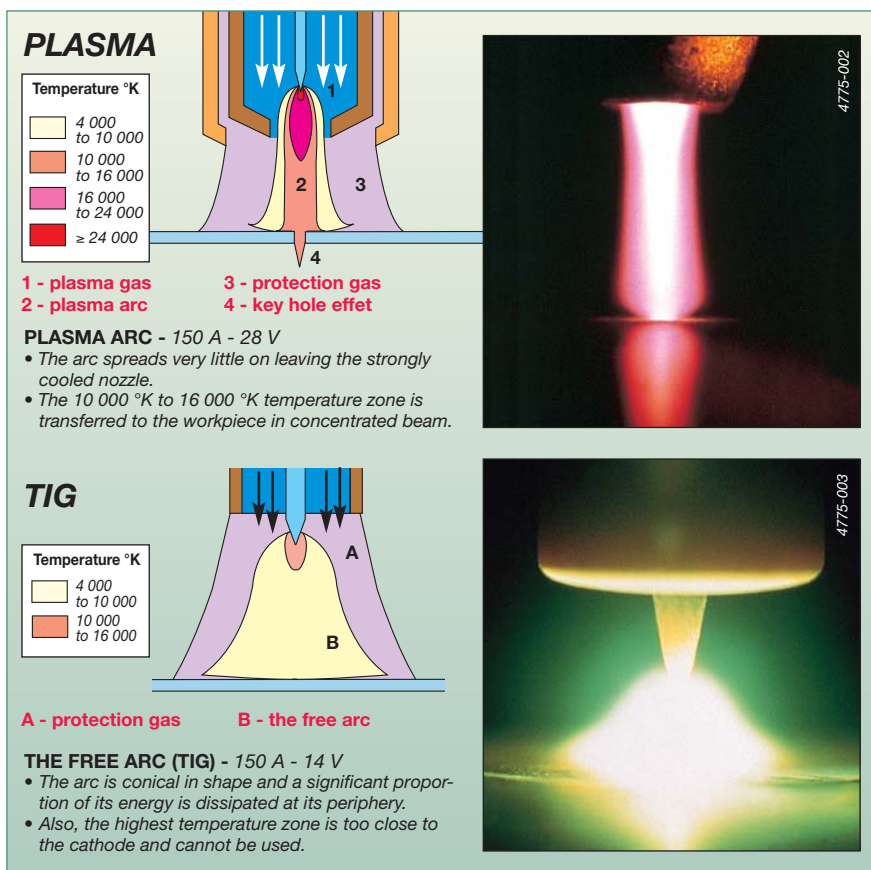

With a free arc (TIG process) the highest temperature zone is too close to the cathode to be usable. The 4 000 °K and 10 000 °K temperature zone is narrow in plasma welding compared to TIG welding where the zone is much wider with characteristic “bell” shape. This zone is not without its uses: it causes surface melting of decreasing depth relative to the plane of the joint, providing a gentle transition from the welded area to the basic metal. This zone is excessively wide in TIG welding and the excess limits performance.

The plasma is made up of excited ions, electrons, atoms or molecules; it occurs in nature, generated by lightning, for example.

Since about 1960, and largely due to Air Liquide Welding, the word plasma has gained a new meaning, referring to the high-energy state caused by constricting an electrical arc by means of a diaphragm or nozzle.

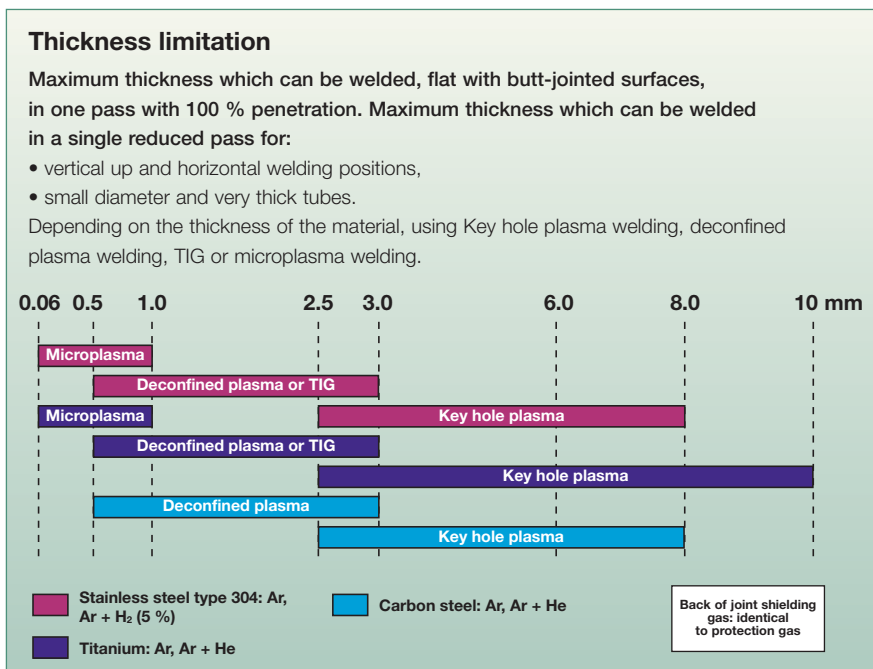

Thickness	Electrode (S.M.A.W)	Manual TIG (G.T.A.W.)	Plasma (P.A.W.)
3 mm			
8 mm			
> 8 mm			

Welding in one pass without preparation: carbon steel and stainless steel, austenitic up to 8 mm, titanium up to 10 mm.

**Example of productivity gain with carbon steel (5 mm):**

- Electrode: preparation + 2 passes at 15 to 20 cm/min grinding.
- Manual TIG: preparation + 2 passes at 10 cm/min.
- Key hole plasma: 1 pass at 40 cm/min.

### Advantages of plasma

- **Rapidity of operation** and **low deformation** to avoid or reduce reconforming operations as well as **low buildup** to eliminate polishing procedures with **respect for the chemical composition of the base material** to avoid problems of corrosion.
- **Excellent visual appearance** which is a quality factor as more and more welds are visible, with **repeatability of the quality** obtained and **a reduction in the preparation times for assemblies** by eliminating bevelling for thicknesses up to 8 mm.
- **4- or even 5- fold reduction in welding times** in comparison with manual welding, with **assurance of complete and regular penetration** by virtue of the traversing jet technique on butted joints.
- **High quality** proof against stringent inspections **with excellent reproducibility**.
- **Produces a faultless weld bead overlap** due to perfect control of the relevant parameters.

# Plasma + TIG welding process

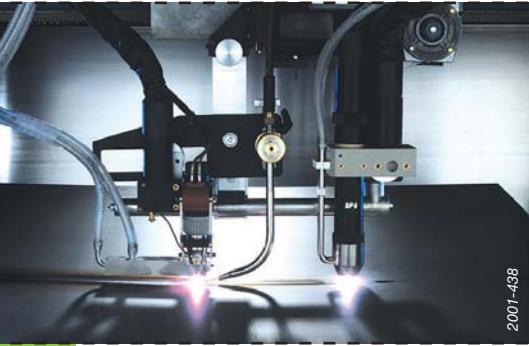

When the length of the panels to be assembled reaches 3 to 4 meters, a boiler-making or tube fabrication workshop using a discontinuous forming process (rolling mill or press) can be restricted by the welding speed obtained with a single-torch plasma process.

Air Liquide Welding, an innovative specialist in TIG and plasma processes, has been able to integrate the two processes into a single installation which can improve productivity by 30 to 50 %.

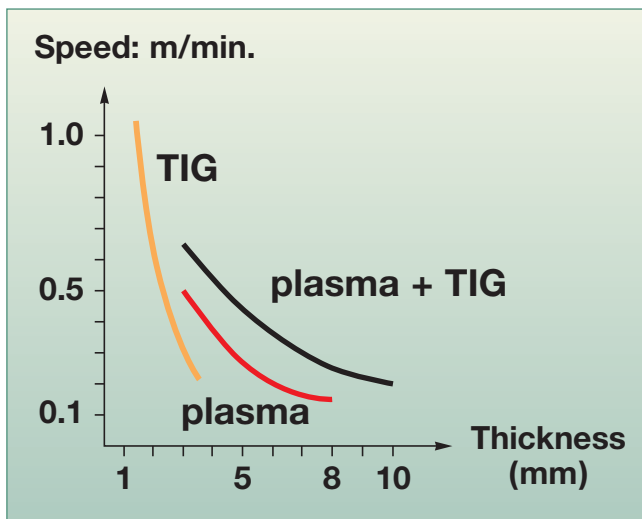

Welding speed (cm/min.)		
Thickness (mm)	plasma	plasma + TIG
3	50	65
4	35-40	50-60
6	25-30	40
8	15-20	25
10	-	20

## Advantages of the plasma + TIG process

- High quality of plasma weld.
- 30 to 50 % increase in productivity.
- Can be adapted to varied boiler-making processes due to its great flexibility.

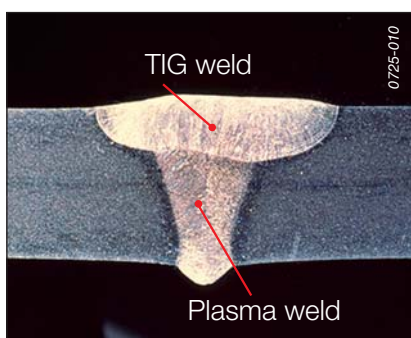

In the plasma + TIG process, the plasma arc first melts the entire thickness of the joint by using a strongly confined plasma which only affects the appearance of the back of the joint. 250 to 300 mm away, the TIG arc equipped with filler metal and a magnetic oscillation system prepares the final appearance of the surface. By virtue of the magnetic oscillation and a 120 mm gas shield, this gives a perfect finish.

**The plasma + TIG process works on thicknesses between 3 and 10 mm.**

Thicknesses less than 3 mm can also be welded perfectly but only a single-torch TIG process is used. Thicknesses greater than 10 mm require an additional single-torch TIG filling pass.

**The plasma + TIG process is specially designed for large capacity stainless steel boiler work:**

- length > 3 meters,
- diameter > 2.2 meters,
- or manufacture of large stainless steel tubes welded in one piece.

# Aluminium welding using the automatic TIG process

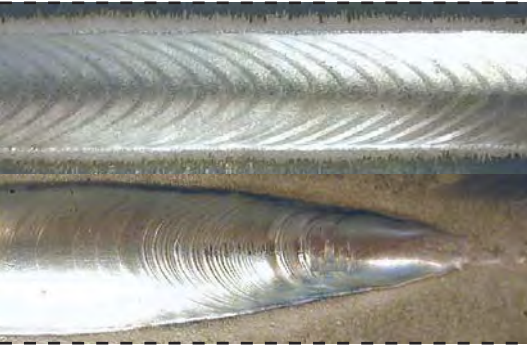

Air Liquide Welding have developed a variation of the TIG process to guarantee success in your automatic welding work. Variable polarity TIG ensures continuous decoating, a high-quality weld bead, total control of the weld pool and perfect fading for finishing off the weld bead.

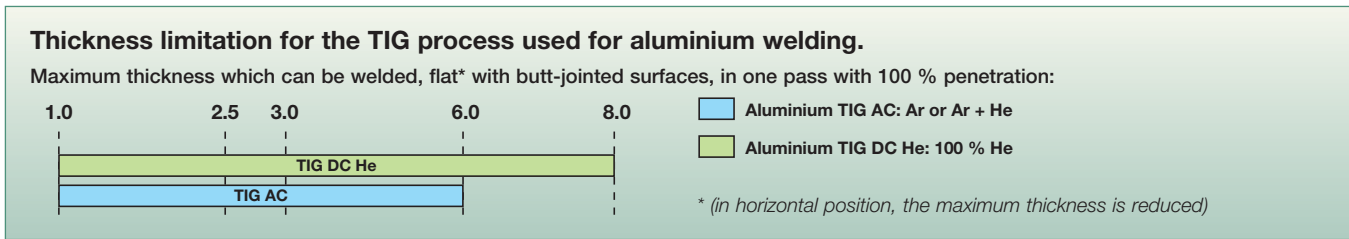

## Alternating variable polarity TIG

The flexibility of variable polarity lies in the total independence of the welding and deoxydising parameters. This means it is possible to optimise the welding and deoxydising phases independently.

This results in better control of the weld pool and better weld bead appearance. The alternations improve weld bead compactness as aluminium and its alloys only too easily show inclusions ( $Al_2O_3$ ) and blisters ( $H_2$ ).

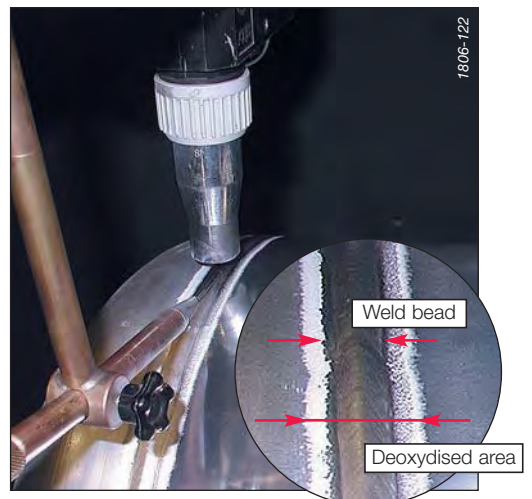
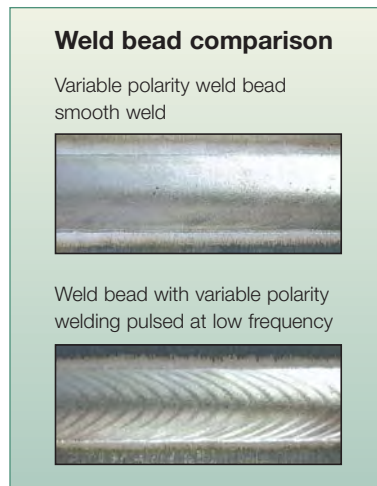
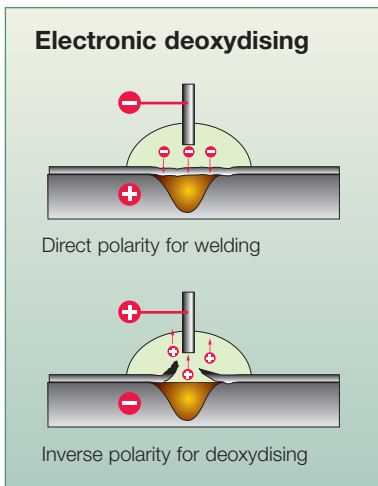
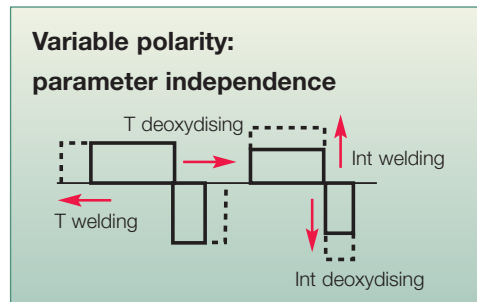

## DC TIG under helium

This process can also be used to weld aluminium with the advantage that, for thicknesses up to 8 mm, it needs only one pass with no preparation.

### Operations to be carried out:

- mechanical oxide loger,
- mechanical support using a backing bar is required for the weld pool.

**Current application:** longitudinal on seamer bench.

**Indicative parameters for DC TIG helium**

Thickness (mm)	Current (A)	Voltage (V)	Weld Speed (cm/min)	Wire Speed (cm/min)	Gas flow rate (l/min)
1.6	100	13	75	110	30
2.0	150	13	75	110	30
2.5	210	13	75	130	30
3.0	220	14	65	200	30
4.0	250	14	45	200	30
5.0	250	14	45	220	30
6.0	300	15	30	220	30
8.0	360	15	18	140	30

One pass with 100% penetration, butt-jointed, position flat.

# Plasma welding in the workshop



Use of plasma or TIG processes or flat longitudinal or circular welding of stainless steel, noble metals, steels or aluminium. Manufacture of all types of product for the petrochemical, agriculture/food processing, aeronautical industries etc.

## Longitudinal welding on seamer bench

### Closing the vessel and even butt-jointing

Start and end of weld on root face.

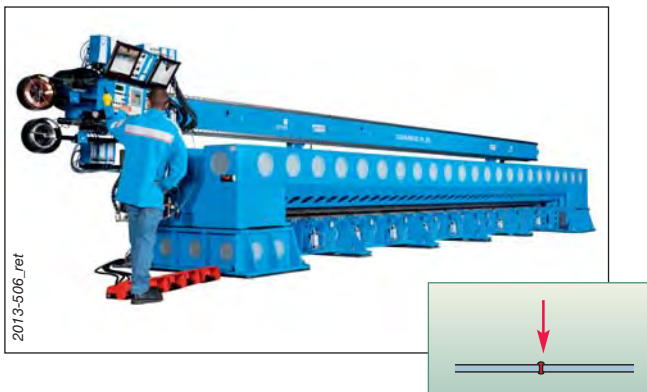
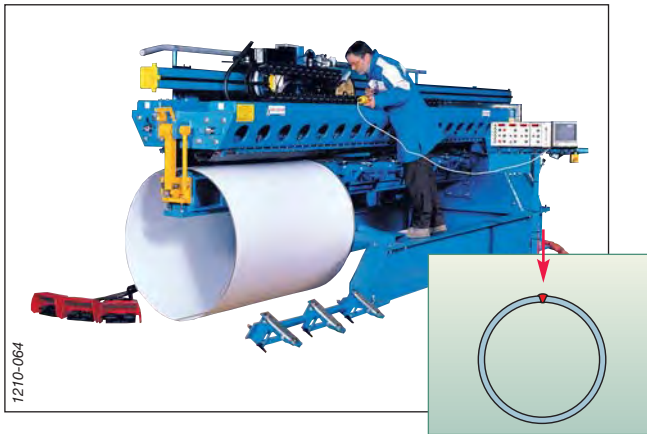
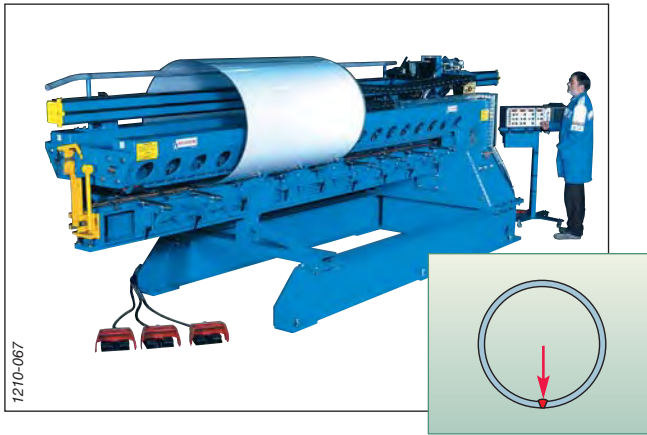

## Standard example of welding in boiler making



### Welding with column and boom

- Maximum standard travel:  
4.3 m horizontal, 6.2 m vertical.

*For other requirements please do not hesitate to contact us.*

### Welding on seamer bench

- Allowable thickness up to 10 mm,
- Maximum weldable length according to type of bench: 4 m (exter), 6 m (exinter) or 7 m (inter).

*For other requirements please do not hesitate to contact us.*



2003-670

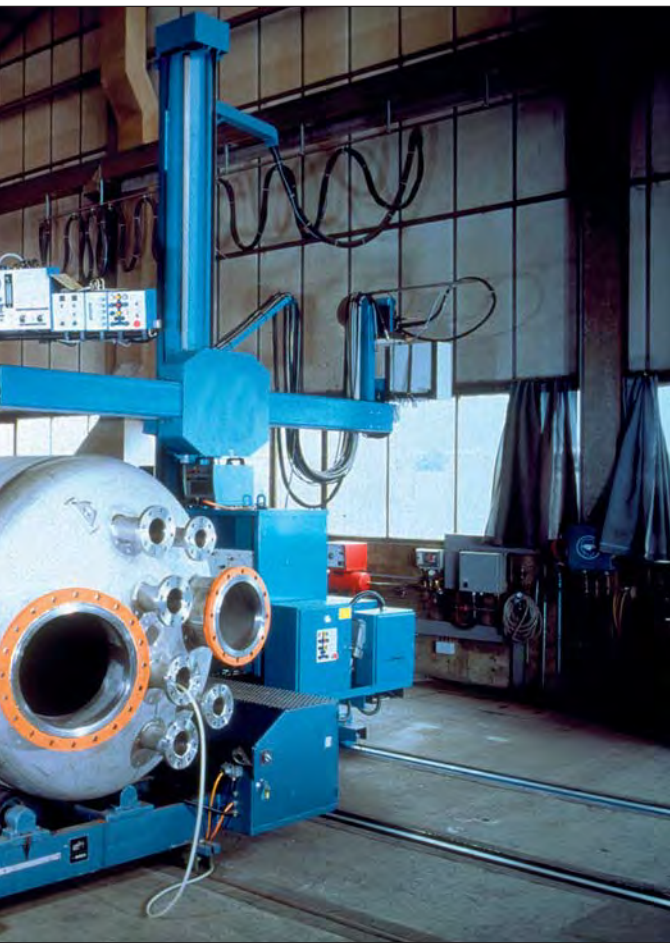

**Elliptical welding with column and boom on rotator.**

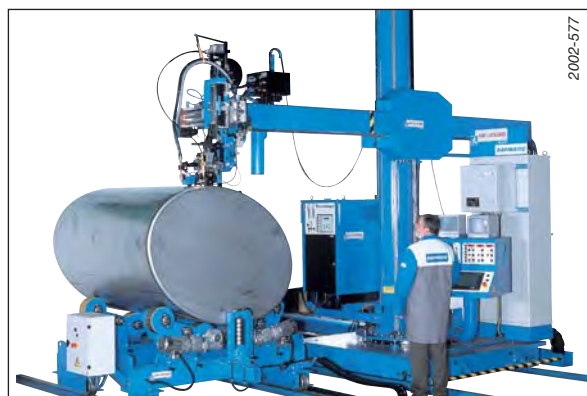

2002-577

**Circular welding with column and boom on rotator or positioner.**

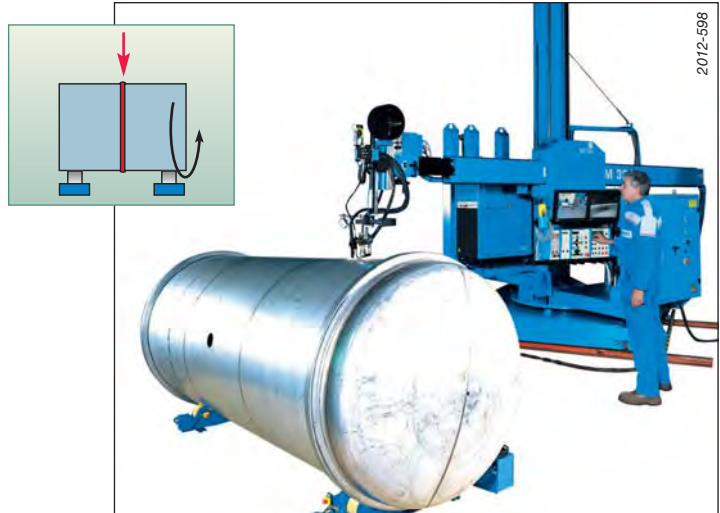

2012-598

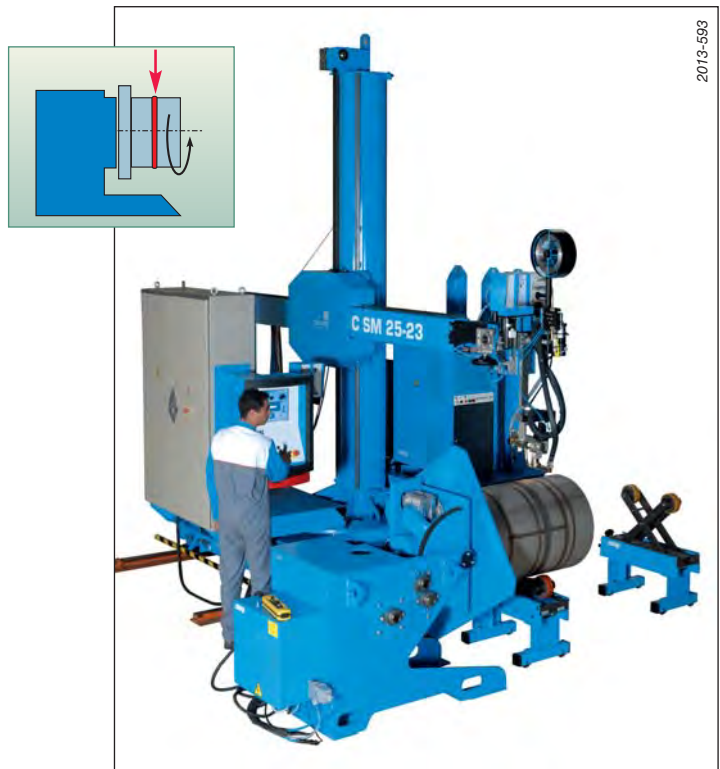

2013-593

# Vertical boiler work

2000-160

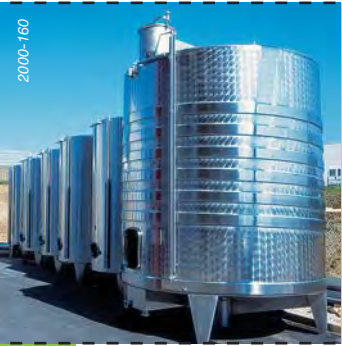

Use of plasma or TIG processes for horizontal welding of stainless steel, noble metals, steels or aluminium. Manufacture of storage equipment for agriculture/food processing, petrochemical industries etc...



1467-003

## Vertical welding

In order for a workpiece to be welded on a rotator it has to be rigid enough (relationship between diameter, thickness and dimensions) to ensure satisfactory stability while welding takes place. For cases where rigidity is not sufficient, or costly (vessel sizing tools), difficult or even impossible to improve because of the large variety of parts used, Air Liquide Welding has produced equipment enabling welding to be carried out "in the vertical axis" where the workpiece is rotated using a horizontal turntable and the torch remains static in the horizontal welding position. This allows very large dimension workpieces to be produced without the use of complex tools.



14450



2000-070

**Turntable capacities:  
5T to 30T.  
For other requirements  
please do not hesitate  
to contact us.**



2000-169

# Plasma welding for prefabricated pipe work



Prefabrication of pipe work is carried out upstream of installation. It enables sub-assemblies to be prepared and welded from basic components (pipes, flanges, elbows etc...) in the workshop. It is used in a variety of industrial sectors:

- shipbuilding and off-shore platforms,
- refineries and power stations,
- chemical and agriculture/ food processing plants,
- gas expansion and distribution stations etc.

The materials used are as follows:

- carbon steels,
- stainless steel,
- noble metals and titanium.

Plasma welding is suitable for prefabricating pipe work of diameter greater than 1.5 inch. Parts with smaller diameters can be TIG welded using the same equipment.

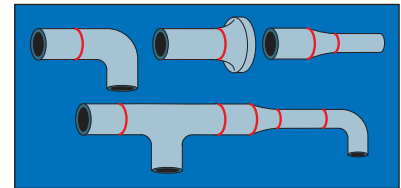

Example of welding times, assemblies are pre-tacked using manual TIG.

Exterior tube Ø	Thickness of wall in mm	Type of steel	Joint preparation	Time taken for plasma welding not counting positioning of assemblies	Time taken for same operation carried out manually
60	2.9	carbon		2 min (2 consecutive passes)	15 min
133	3.8	carbon		4 min (2 consecutive passes)	24 min
406	9.52	carbon		14 min (2 consecutive passes)	24 min
114	8	AISI 304		4.15 min (2 consecutive passes)	38 min
170	3.2	AISI 304		2 min (1 pass)	55 min

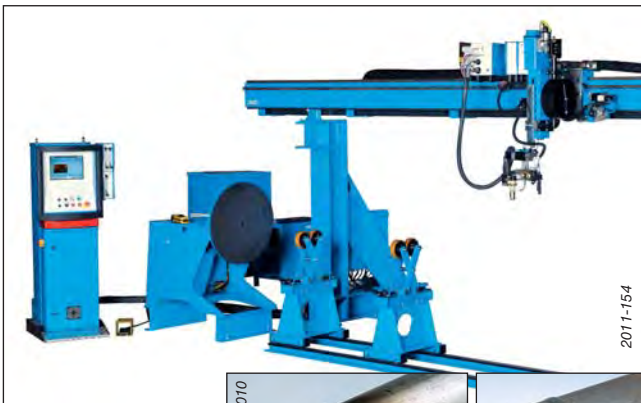

# TIG and plasma installations

## Applications

Multi-purpose welding installation to enable the following processes to be used in automatic applications:

- DC TIG with smooth or pulsed current
- AC TIG with variable polarity,
- DC plasma with smooth or pulsed current.

This installation meets the highest quality standards for welding and productivity for industries as diverse as boiler-making using stainless steels, aeronautics using noble metals, chemical engineering, energy production, transformation and transport as well as prefabrication of gas and petrol pipes etc.

## General composition

TIG/plasma installation allows a complete process management integrating the control of current, voltage, wire speed, gas flow, welding speed, magnetic oscillation...

Advanced functions for an accurate Key-Hole closure, pulsed wire, PLC interface, PC software.

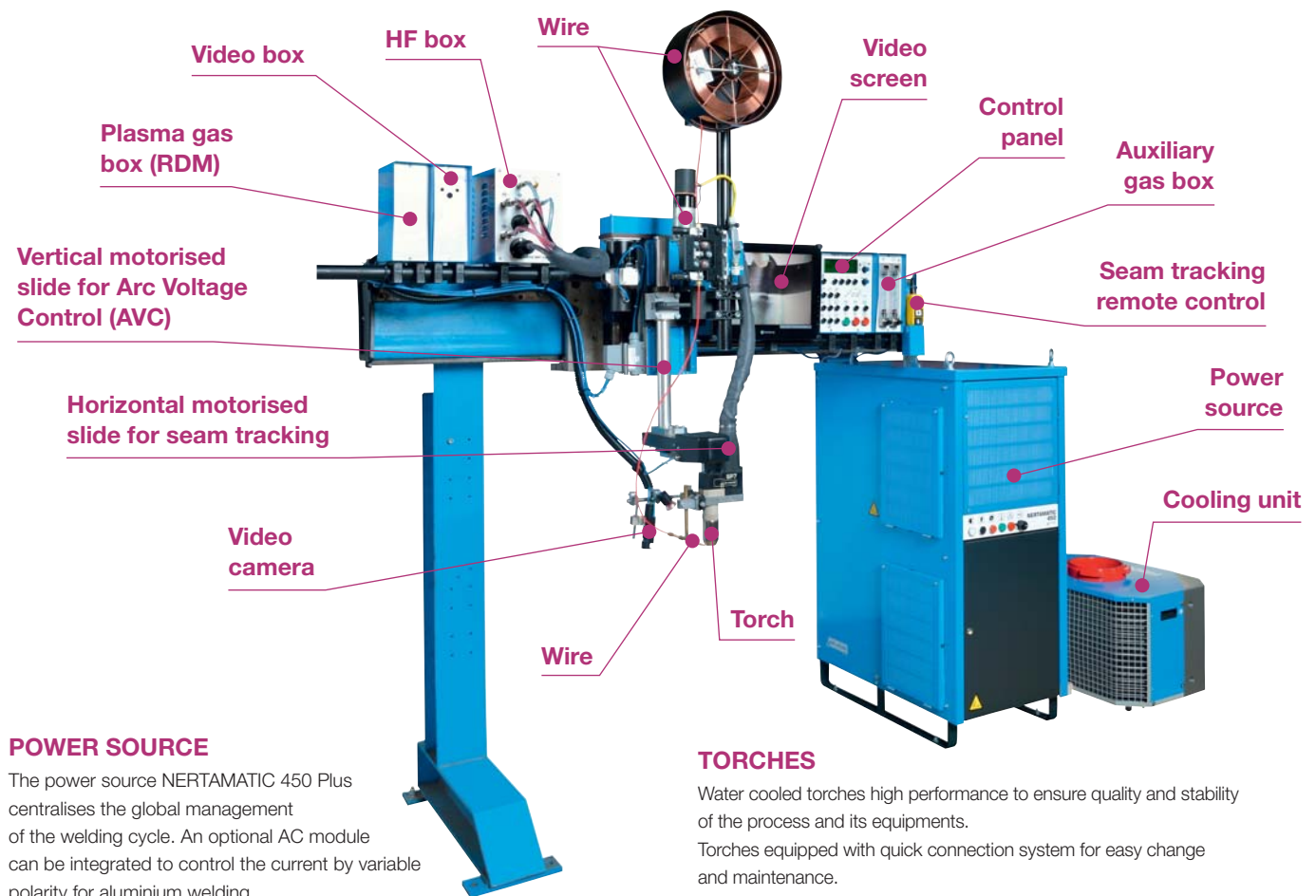

## POWER SOURCE

The power source NERTAMATIC 450 Plus centralises the global management of the welding cycle. An optional AC module can be integrated to control the current by variable polarity for aluminium welding.



	Technical features
Primary power supply	230 V - 400 V - 415 V - 440 V - 50Hz/60 Hz
Power consumption	22 kVA
Duty cycle	450 A @ 100%
Pulsed current	1 to 100 Hz
AC current	50 to 200 Hz
Data exchange	USB
Protection class	IP23
Weight and dimensions	270 kg 1200 (h) x 500 (w) x 850 (d) mm

## TORCHES

Water cooled torches high performance to ensure quality and stability of the process and its equipments.

Torches equipped with quick connection system for easy change and maintenance.

### SP7:

This torch is the reference in the market, for soft and key hole plasma welding.

- 450 A at 100%.
- Standard electrode simple to replace and self-aligning.
- Cold massive nozzle ensuring long life time.



### Options:

- Gas trailing shield to protect welds in sensitive metals.

### MEC4:

- For TIG welding
- 500 A at 100%.
- Standard electrode easy to replace.
- Twin HF ignition for better arc striking.



### Options:

- Gas trailing shield to protect welds in sensitive metals
- Magnetic arc oscillation.

## PLASMA GAS

For thicknesses greater than 2.5 mm, plasma welding uses the Key-Hole technique.

If one cuts the arc current off instantly, a hole remains on the work piece.

In order to remedy this disadvantage on circular welding, and in order to make the Key-Hole disappear, it is necessary, before extinguishing the arc, to gradually reduce the torch's plasma gas flow simultaneously with the arc current. This complement allows this with a numerical valve for plasma gas management.

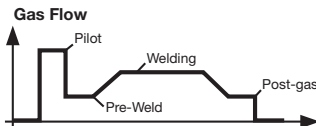

Gas flow range: 0 to 10 l/min  
Accuracy: 0.1 l/min

## AVC SYSTEM

A constant distance between the torch and the workpiece is a key of quality to ensure a constant penetration and bead width.

The Arc Voltage Control (AVC) keeps this constant distance by automatic regulation of the arc voltage: function fully integrated into the ALW system composed of an electrical vertical slide travel 200 mm.

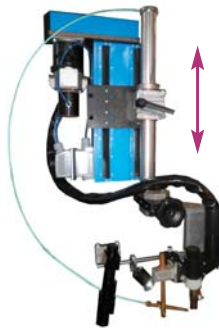

## OSCILLARC PLUS

Arc deviation

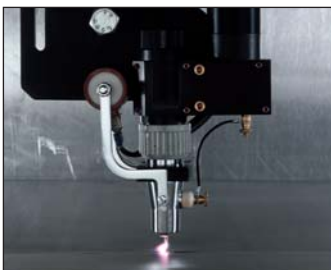

This technique is used to electrically deflect the TIG arc forward in the welding axis, increasing the speed by 30 to 50% for thicknesses of less than 2 mm.

Arc oscillation

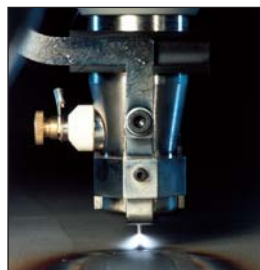

Arc oscillation is used to deposit metal over areas up to 15 mm wide to fill bevels or reconstitute surface coating.

## VIDEO CAMERA

The TIG/plasma video system VISIOARC VA2 can be easily integrated.

It uses a greatly enlarged image which enables the precise position of the welding torch. The operator can then work at remote distance of the welding head; working easier and improving the quality of the welding operations.

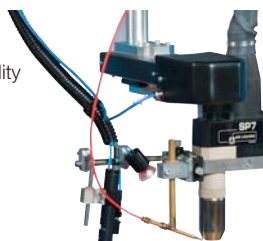

System with large color screen 15", miniaturised camera and additional lighting

## WIRE FEED DEVICE

It is often necessary to feed the melting bath with metal during the operation in order to prevent the seam from showing hollows, to supply soft steels with deoxidizing elements, for successive seams.

The proposed system allows to quickly and accurately adjust the wire impact point in the welding pool thanks to micrometer slides.

The adjustment can be manual or motorised for a remote control with a video system.

	Characteristics
Carbon steel Stainless steel Titanium wires	Ø 0.8 / 1.0 / 1.2 mm
Aluminium wire	Ø 1.2 / 1.6 mm
Max wire speed	6 m/min

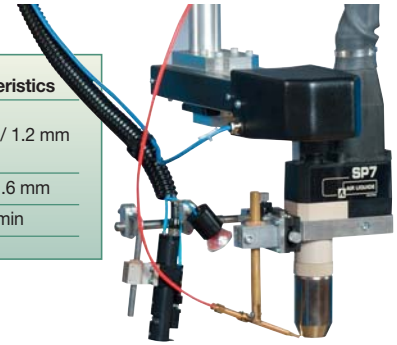

## COOLING UNIT

The FRIJET 300 cooling unit is compact with coolant constant supply, in closed circuit, used to cool down torches.

	Characteristics
Primary supply	230 V / 1 ph / 50 Hz
Nominal water flow rate	6 l/min
Nominal water pressure	5 bars

Directly supplied by power source NERTAMATIC 450

## HOT WIRE

Productivity improvement by increasing the deposition rate

For filling bevels, the use of hot filler wire provides a good solution and is particularly suited to applications where a high specification of the welded joint is required.

This special technique uses an auxiliary current to bring the end of the wire to nearly melting point.

Viable for plates of thickness 10 mm and above, the use of hot filler wire enables 2.5 to 3 kg of metal to be deposited per hour for filling bevels using multiple passes or for quality hard-surfacing.

- Additional power source for the current hot wire between 60 A and 120 A.
- No additional wire feed thanks to a direct connexion on the cold wire system.



# TIG and plasma installations

For TIG/plasma welding process, Air Liquide Welding proposes two types of control system.

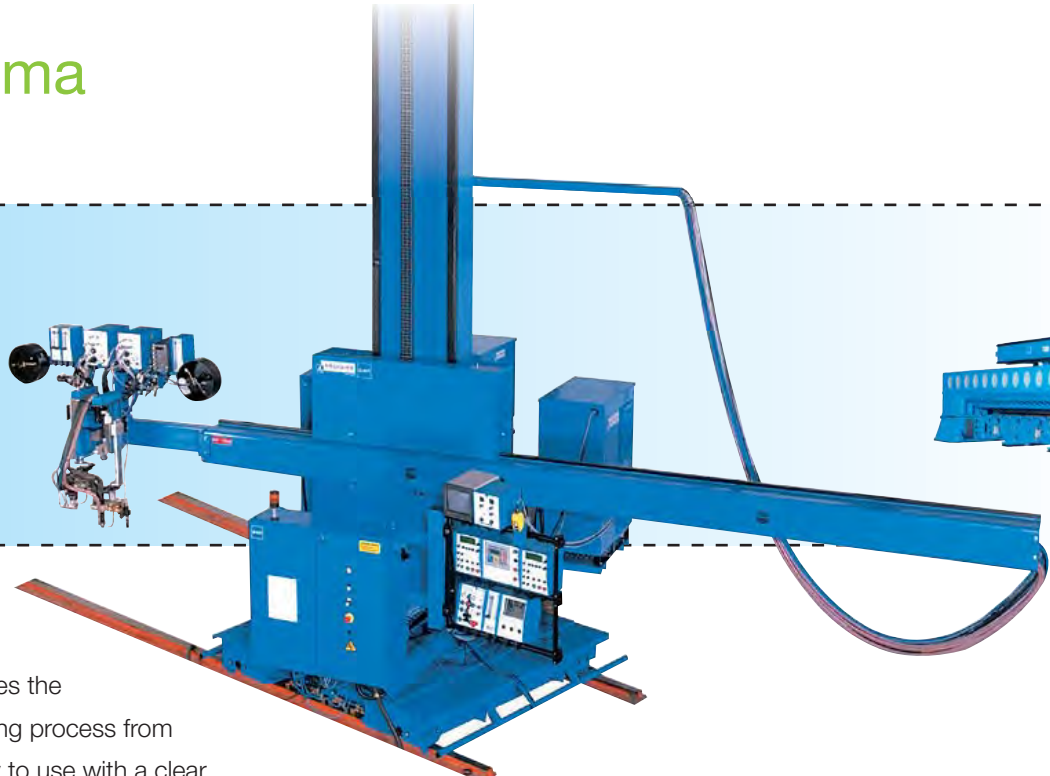

## NERTAMATIC 450 Plus

NERTAMATIC 450 Plus integrates the management of complete welding process from a central panel, robust and easy to use with a clear text LCD screen display of 4 lines of 20 characters which allows:

- Storing of 50 welding programs (voltage, current, wire speed, plasma gas, movement speed, magnetic oscillation).
- Parameters modification during welding.
- Cycle start/stop, manual control of gas/wire/AVC/movement.
- Complete management of key hole closure.
- Pulse current settings for fine thickness welding and vertical or cornice position.
- Easy integration and communication with external PLC thanks to Open PLC function.
- Import/export via USB key for uploading or downloading programs.
- Edition of programs on external computer. Thanks to Off-line software.



Tools edit programs and create WPS

## Tandem process plasma + TIG



Plasma + TIG tandem process allows to improve productivity by 30% to 50% compared to a single plasma torch. The installation is composed of:

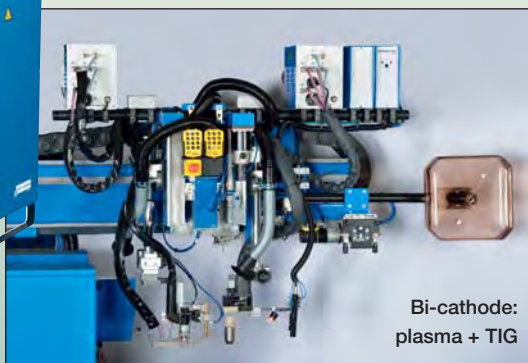

Bi-cathode: plasma + TIG

- 2 power sources NERTAMATIC 450
- 1 plasma SP7 torch
- 1 TIG MEC4 torch
- 1 control system N450 Plus or HPW.
- 2 AVC
- 1 video camera on plasma torch
- 1 wire feeding system on the TIG torch
- 1 gas trailing shield on TIG torch
- 1 oscillation system on TIG torch

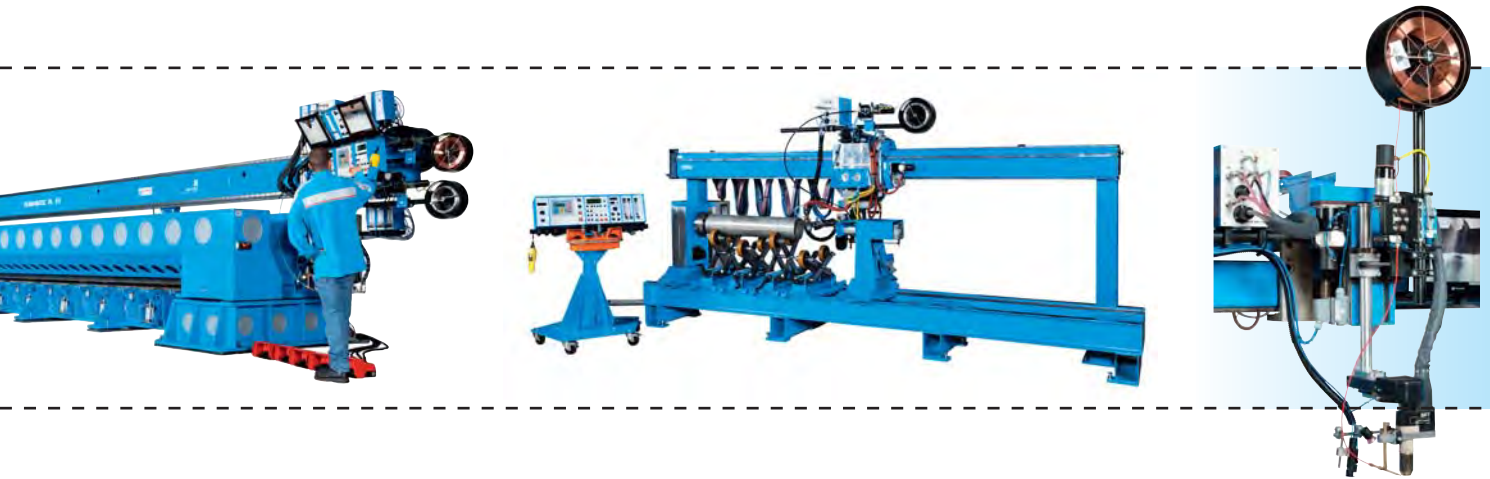

## HPW

HPW NERTAMATIC 450 is an industrial PC allowing the global management of complete welding process and machine axes. Its main characteristics are:

- Touch screen with a friendly and intuitive interface allowing the programming, controls and follow up
- Numerical management of the welding process, its associated movements and drive units via industrial PC.

- Traceability, a program integrates all the parameters allowing the repetitivity of the welding.
- Quality follow-up in option, record and storage of the essential parameters of welding (current, voltage, gas, wire feeding, movement).
- Wireless remote control option.
- Import/export via USB key for uploading or downloading programs and WPS edition.



### Welding



### Programming



### Configuration



### Quality (as a option)



Wireless remote control

## NERTAMATIC 450 Plus P+T

2 control panels NERTAMATIC 450 Plus associated with "D2C" PLC for a complete management of the P+T cycle



## HPW P+T

Plasma + TIG function completely integrated in the numerical control HPW. Global management of the welding program.



# Deconfined plasma

2003-024

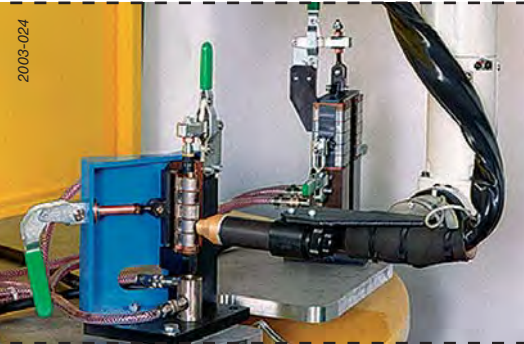

The SP150 torch is specially built for automatic welding using the deconfined plasma process. It is used for intensive production and is suitable for all machine types. The most recent applications are the production of melt-runs, small weld beads or very repetitive welding.

The installation can also use the control arc double-flux TIG process using smooth or pulsed current. Plasma is an evolution of the TIG process which brings many opportunities for increasing your productivity.

## Using a permanent control arc

- No more HF priming for each weld bead, only the transfer of a control arc which guarantees repeated priming with less waste and client peripherals protected.
- Reduction of slack time between two welds.

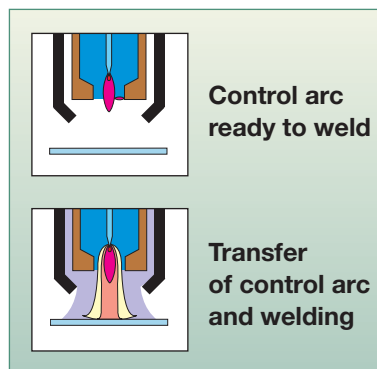

## By using an electrode protected by the nozzle,

The lifetime of the electrode is increased with a consistency of weld maintained over 8 hours (sometimes more depending on the material and weld types) resulting in a reduction of machine stoppages for grinding.

## Applications of deconfined plasma

### In boiler making and sheet metalwork

Fine thicknesses from 0.4 to 2 mm.

### In mass production

Household appliances, radiators, automobile engine air liqueur welding points, electrical construction (welding electrical sheets for alternators or transformers).



- 1 - Alternator or motor cores,
- 2 - Automobile pipe work,
- 3 - Welding gates onto radiator segments,
- 4 - Deburring beer barrel handles by plasma refusion.

## Basic installation:

- SP150 welding torch equipped for plasma or double-flux TIG,
- torch connection block,
- harness of length 10 m specific to plasma,
- one power source for the pilot arc,
- one power source for welding.



# MICROPLASMA

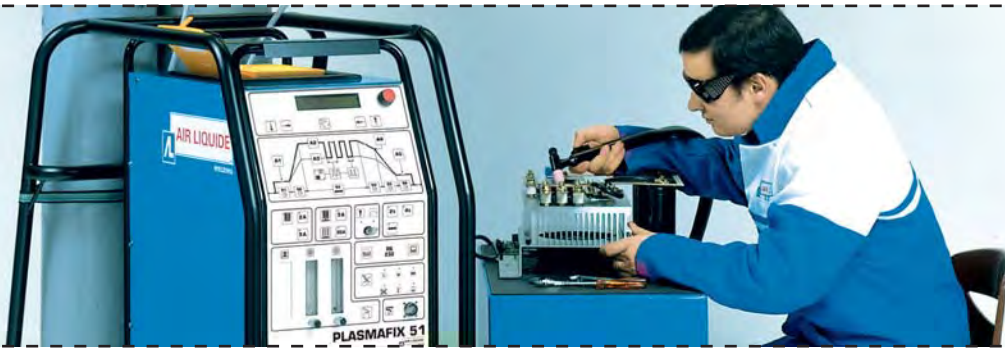

## Manual and automatic welding applications

For the manual or automatic assembly of thin precious metals in the thickness range: 0.05 - 1.0 mm (stainless steels, Inconel, titanium, silver and gold alloys).

For the electric and electronics components industries, small containers, metal filters and tool repairs as well as sectors of the horology, goldsmith and medical industries.

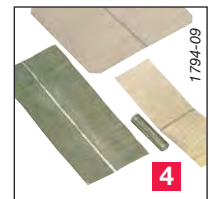
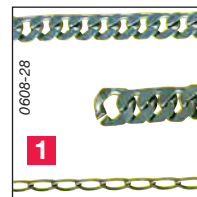

## Installation

### PLASMAFIX 51 Characteristics:

- User friendly front panel
- Multilingual display
- Totally programmable welding cycles
- 100 programmes memory
- Configuration which is adapted to the user's needs
- Programme print out.
- Also for TIG welding
- Equipped of RS 232 for coupling a P.C or printer
- Cooling by a liquid
- Tungsten electrodes: Ø 1.0 or 1.6 mm, 75 or 150 mm long

Installation with cooling unit on trolley



## Torches

Two types of torch for use in manual or automatic mode:



SP45 automatic



SP45 manual

An SP20 manual or automatic torch can be supplied on request. This weighs considerably less and has a maximum current rating of 20 A at 100%.

1 - Jewellery

2 - Fine sheet metal work

3 - Small containers

4 - Filters

## Complements

### Welding lathes

Precision circumferential machine for microplasma and TIG welding.

### Trolley

Able to receive the PLASMAFIX 51 power source, the cooling unit and two gas bottles.

### Double welding command pedal

(replaces the torch trigger)

### Trigger and current adjustment pedal

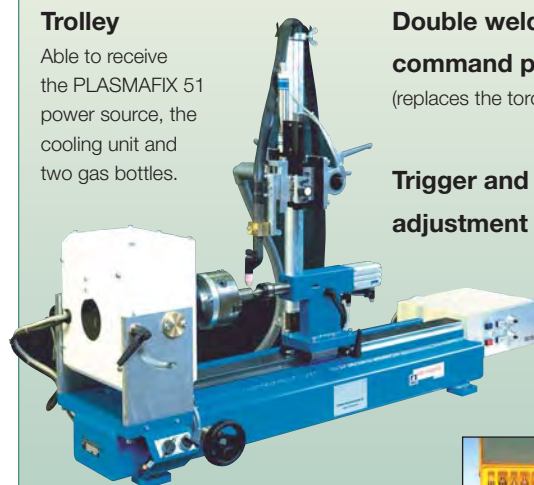

Torch maintenance box with set of wear parts

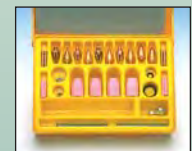



## Contacts

AIR LIQUIDE WELDING FRANCE  
13 rue d'Epluches  
CS 10113 Saint Ouen l'Aumône  
95315 Cergy Pontoise Cédex - France  
Tél. : + 33 1 34 21 33 33  
Fax : + 33 1 34 21 31 30

[www.airliquidewelding.com](http://www.airliquidewelding.com)

## Contacts for other countries:

### Air Liquide Welding Export Department Italy

Via Torricelli 15/A  
37135 VERONA  
Tél.: +39 045 82 91 511 - Fax: +39 045 82 91 536

### Air Liquide Welding Export Department France

13, rue d' Epluches  
CS 10113 Saint-Ouen l'Aumône  
95315 CERGY-PONTOISE Cedex  
Tél.: +33 1 34 21 33 33 - Fax: +33 1 30 37 19 73



**Air Liquide is the world leader in gases for industry, health and the environment**, and is present in over **80 countries** with **50 000 employees**. Oxygen, nitrogen, hydrogen and rare gases have been at the core of Air Liquide's activities since its creation in 1902. Using these molecules, Air Liquide continuously reinvents its business, anticipating the needs of current and future markets. The Group innovates to enable progress, to achieve dynamic growth and a consistent performance. Air Liquide combines many products and technologies to develop valuable applications and services not only for its customers but also for society.